

T-MAXX FORWARD ONLY SHAFT INSTALLATION

Please refer to the T-MAXX operating instructions for removal of the transmission from the chassis. If you have any questions, call or E-mail Traxxas' technical support department. Technical support is available Monday through Friday, from 8:30 AM to 9:00 PM Central Time at **(888)TRAXXAS** (U.S.A. residents only). Outside U.S.A. call (972) 265-8000. Technical assistance is also available thru our website at **WWW.TRAXXAS.COM** 24 hours a day. Email Traxxas at **support@traxxas.com**

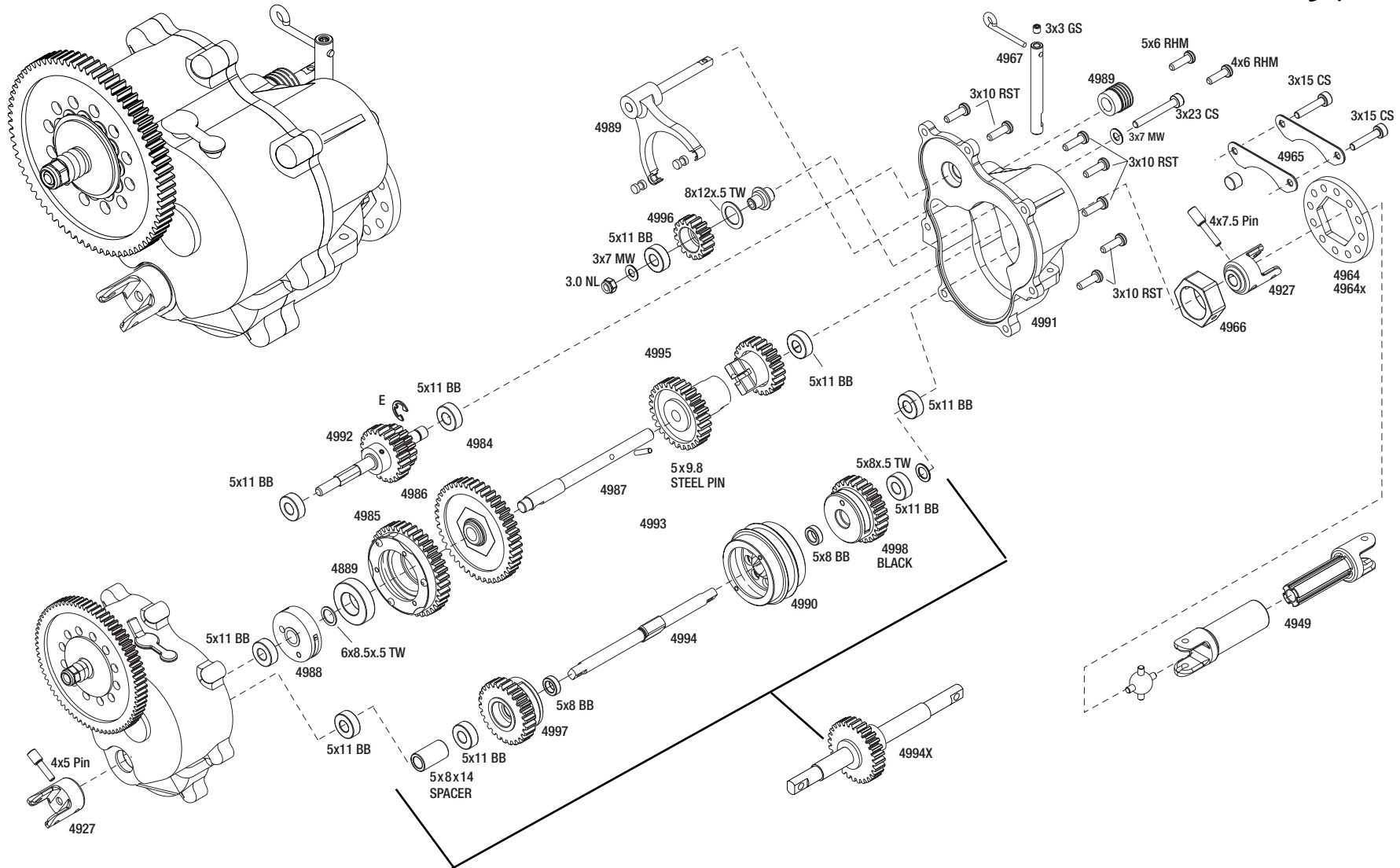
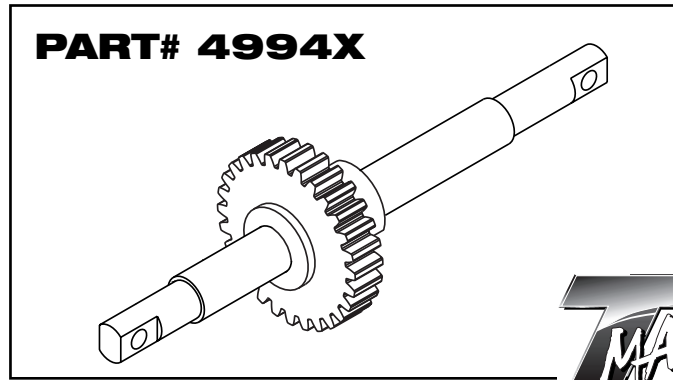

1. Remove the transmission from the chassis by removing the (8) 3x15mm roundhead machine screws. See the exploded views in the operating instructions.

2. Remove the set screw pin (4x5), and the output yoke (4927) and set them aside.

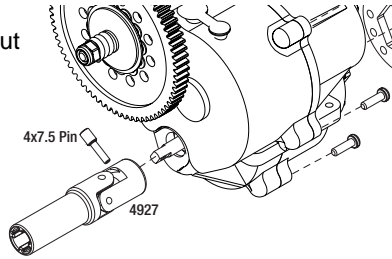

3. Rotate the disc brake so that the yoke set screw (4x7.5) faces down. Push the disc back to allow access to remove the set screw. Remove the yoke (4927), hex brake adapter (4966), and the disc brake (4964).

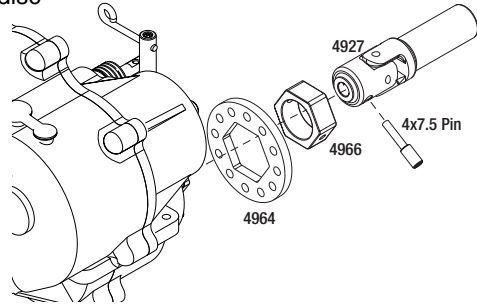

4. Remove the seven 3x10 roundhead self tapping transmission case screws, and set them aside. Carefully pull the front half (spur gear side) of the transmission off.

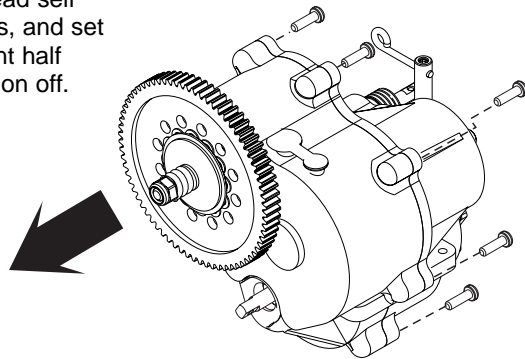

5. With the transmission case open, remove the two-speed drive assembly. Keep the two-speed assembly together and set it aside.

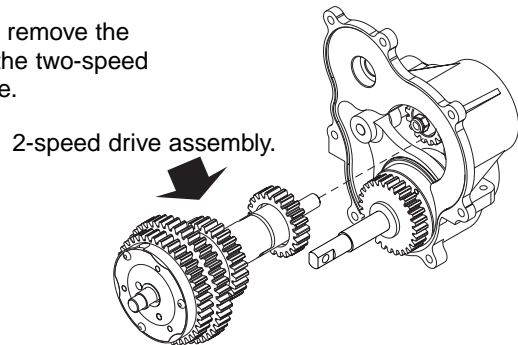

6. Remove the ball screw from shift-fork shaft. Remove the forward/reverse output shaft assembly along with the shift fork shaft (4989). The output shaft assembly and shift fork assembly will not be used in the forward only upgrade.

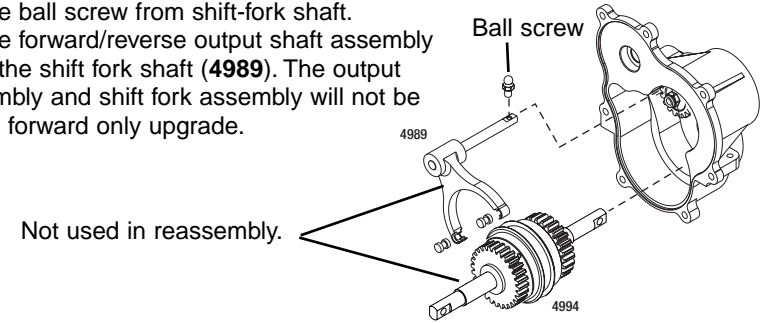

7. Remove the Idler gear assembly (4996). The idler gear assembly will not be reused.

Use a pair of needle nose pliers to remove the shaft from the case.

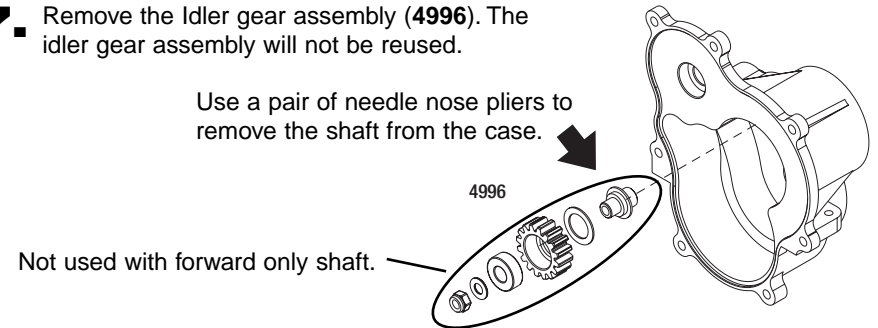

8. Replace the shift fork shaft seal with the included 5x6 roundhead machine screw. Use a 4x6 roundhead machine screw to plug the idler gear hole.

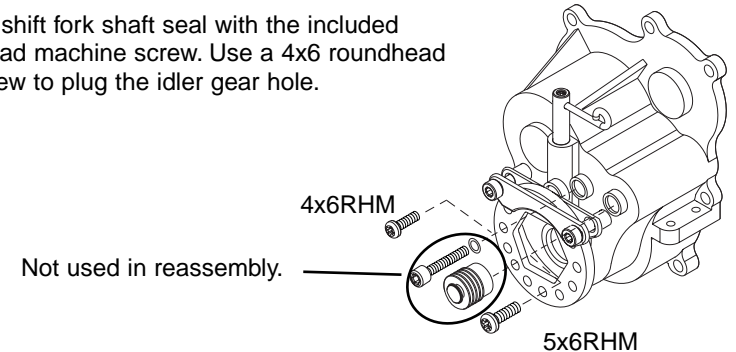

9. Install the forward only shaft (4994x) replacing the forward/reverse output shaft assembly. Install the longer end of the output shaft towards the disk brake side of the transmission. Install the two speed assembly. The transmission case can now be reassembled. Reverse the disassembly procedure (steps 1-6) to reassemble the transmission. Remember to hook up the drive shafts when reinstalling the transmission in the truck.

